



# HIRSCHMANN

A BELDEN BRAND

## New Product Bulletin

PB 1048LE-AG

### Hirschmann® GDM-Series Valve Connectors

Provide high operational safety by protecting downstream electronic components and the visualization of the operating status makes it easy to maintain your application.



### The High Profile of the GDM-Series Valve Connectors can be Rapidly Assembled and Put into Operation while Enabling Sustainable Cost Reduction.

The newly developed valve connectors from the Hirschmann GDM-series are offered in type A and are available either with protective circuitry or in a version with additional LEDs. Both versions have integrated strain relief and are compliant with UL 2238, while providing maximum protection for your applications. The connection technology comes from the Hirschmann tried-and-tested GDML-series.

Thanks to their configurability and incorporating an optional choice of new materials, these valve connectors are able to provide secure solutions for a wide range of environmental conditions.

- Easy connection of cables and reliable contacting ensure increased productivity
- Wide range of cable gauges – from finely stranded to solid conductors – offers maximum flexibility
- High level of shock and vibration resistance coupled with protection ratings up to IP68 guarantees maximum functional security

### Applications:

The GDM-series valve connectors are particularly suitable for use in the machine building and tool and equipment manufacturing. They facilitate both reliable power supplies and secure data transmission for components such as magnetic valves, pressure transducers, temperature sensors and flow monitors: integrated protective circuitry ensures that downstream electronic components are unaffected by voltage surges or electromagnetic interference. In short: they deliver a high level of operational safety.

### Benefits:

These new valve connectors provide simplified cable connection and reliable contacting, while ensuring a solid increase in productivity. Thanks to the wide connection area, the assembly of the connectors is easy to install on site. In addition, their high level of shock and vibration resistance coupled with industrial protection up to IP68 provides a maximum operational reliability.



# HIRSCHMANN

A BELDEN BRAND

Optimal LED radiation behavior thanks to innovative design.

## Functionally Reliable and Easy to Maintain

Valve connectors from Hirschmann are remarkable for their innovative design with rounded edges. Non-slip surfaces on both sides ensure safe handling. The high profile and contacts are easy to assemble and put into operation while special circuitry provides reliable protection for downstream electronics. These features are planned for integration in future designs.

The material of the housing is configurable, enabling the connectors to be customized for different applications. The housing materials provide a variety of options ranging from temperature and acid-resistant structures to fully biologically recyclable solutions.

### The Advantages at a Glance:

- Electronic inserts with function display (LED) and/or circuitry protect downstream electronics
- Protruding gripping surface on both sides for easy handling
- High profile for easier connection and commissioning
- Optional version with strain relief compliant with UL 2238
- High shock and vibration resistance
- Extended temperature range from -55°C to +90°C (may vary, depending on the configured material)
- High protection rating up to a maximum of IP68
- Ideal addition to the Hirschmann portfolio of valve appliance connectors and to connectors and bulk stock cables of Lumberg Automation™, which offers versatile and optimized solutions for various environmental conditions.

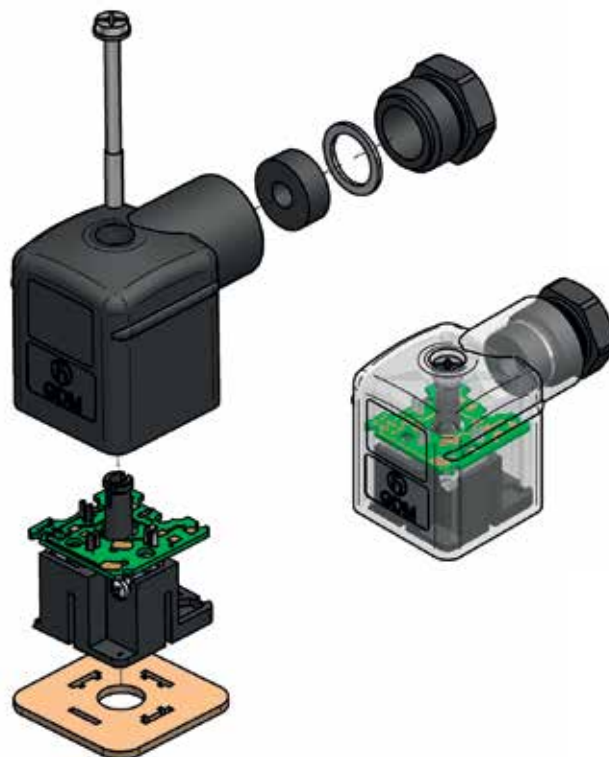



## Technical Information

Product Description	
Type	<b>GDM-Series Valve Connectors</b>
Standards	EN 175301-803, Type A
Number of Contacts	2+PE, 3+PE
Cable Gland	M16/PG9 (M20/PG11 in preparation)
Conductor Size	max 1.5 mm <sup>2</sup>
Suitable Cables*	M16/PG9: 4.5 mm to 10 mm max. (M20/PG11: 4.5 mm to 14 mm max.)
Technical Data	
Rated Voltage*	AC/DC 12, 24, 48, 120 und 250 V
Rated Current*	AC/DC 10 A (with bridge rectifier AC/DC 1 A)
Protection Class*	IP65/IP67 (IP68 on request)
Operating Temperature*	-40°C to +90°C (-55°C to +125°C on request)
Locking	
Central Screw	M3 x 35
Flammability Class	
Housing*	94 HB
Contact*	94 HB
Approvals	
VDE	in preparation
UL	in preparation
CSA	in preparation
Circuitry Versions	
C1	RC circuit
C2	RC circuit, function indicator filament/neon lamp
C3	RC circuit, function indicator LED
C4	Varistor/bridge rectifier/capacitor
D1	Recovery diode
D2	Recovery diode, function indicator LED
D3	Bridge rectifier
D4	Bridge rectifier, function indicator LED
L1	Function indicator LED
P1	Function indicator for pressure switch (normal open)
P2	Function indicator for pressure switch (normal closed)
S1	Suppression diode
S2	Suppression diode, function indicator LED
S3	Suppression diode/bridge rectifier
S4	Suppression diode/bridge rectifier, function indicator LED
S9	Universal protective circuit 12 – 250 V
V1	Varistor
V2	Varistor, function indicator LED
V3	Varistor/bridge rectifier
V4	Varistor/bridge rectifier, function indicator LED

\* Deviations are possible depending on the product configuration



# HIRSCHMANN

A BELDEN BRAND

[www.hirschmann.com](http://www.hirschmann.com)

## The Hirschmann Competence Center

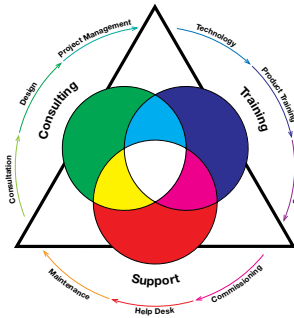

Hirschmann provides an economical end-to-end solution for your network. In addition to its well-known products, Hirschmann also offers a wide range of vendor-independent services - whether it is consulting, training or support. At the Hirschmann Competence Center, you can be sure of tailored service from a single supplier.

Whichever technology you use, our experts will support you all the way, from designing your network to optimizing the performance required in the operational phase. The most current technological and product expertise, an international service and support network and fast access to external specialists guarantees you the best possible support. Bundle your individual service package today!

To learn more about the Hirschmann Competence Center or to register for sessions go to:

[www.hicomamericas.com](http://www.hicomamericas.com)

### Always the Right Solution

Belden is the world's leading supplier of signal transmission solutions including cable, connectivity and active components for mission-critical applications ranging from industrial automation and alternative power generation through to professional broadcasting. Belden offers an extensive portfolio of highly specialized products for steering, control and field level, which the company produces and markets under its proprietary Belden®, Hirschmann™, and Lumberg Automation™ brands. We would be glad to give you a more personal introduction to our integrated product palette for industrial applications and the worldwide Belden Service

We guarantee the superior performance of your mission-critical systems, even in the most demanding circumstances. If signal transmission is vital to your business, get in touch with the partner that delivers. Be certain with Belden. You can find further information and technical details online at [www.beldensolutions.com](http://www.beldensolutions.com) or contact our Sales Team directly: **Tel. 717.217.2299**.