

PB0004LA-AG

**Lumberg Automation™
RSCIS 4D/9 and BRSCIS
4D/9 Connectors**

Field attachable connectors – with patented insulation-displacement technology – enable convenient set-up of EtherNet/IP and PROFINET connections, meeting various challenging industry standards.



Designed for challenging conditions, these M12 Industrial Ethernet field attachable connectors are ideally suited for rolling stocks and on-machine applications, where extended temperature ranges and global certifications for industrial standards apply.

- Ease of installation – minimal installation time is needed due to the connectors' patented insulation-displacement connector (IDC) technology, which ensures exceptional mounting characteristics to enable a significant increase in efficiency for customers.
- Reliability – the shielded connectors also allow for highly-reliable performance and maximum network uptime in environments where electromagnetic compatibility (EMC) is required.
- Flexibility – suitable for applications that require fulfillment of the highest European railway standards.
- The RSCIS 4D/9 connectors are designed specifically to meet the safety and quality needs of automotive, machine building and material handling applications, and will also carry UL's seal of quality in the near future.
- The BRSCIS 4D/9 connectors are proven for use in railway applications – according to Europe's stringent DIN EN requirements for rolling stocks – where vibration and inflammability pose constant challenges to the reliability of transportation systems and safety of the people traveling.

To offer network engineers, system integrators and machine builders the most efficient solution for establishing EtherNet/IP and PROFINET connections in the field, the new Lumberg Automation™ connectors feature a patented insulation-displacement technology for a highly-reliable and efficient data connection. With IDCs, installers are no longer required to strip the wire of insulation before connecting. As part of the patented IDC concept, the connectors also require minimum force during assembly and mounting – saving customers significant time and effort compared to other connectors on the market.

Applications

The RSCIS 4D/9 and BRSCIS 4D/9 connectors, while with many similar technical specifications, each offer specific features for certain applications.

Your Benefits

The best-in-class IDC concept within the RSCIS 4D/9 and BRSCIS 4D/9 connectors enables an easier and faster on-site installation, reducing the downtime of equipment significantly. Additionally, a left hand thread between the connector and IDC body allows for fool-proof attachment to other interfaces.

Further, for applications where space constraints are an issue, the RSCIS 4D/9 and BRSCIS 4D/9 connectors are approximately 10 percent smaller in diameter than the market standard for IDC connectors – making them easier to handle and install.

The benefits of these products have been made with customer feedback in mind – related to the need for easy installation, time savings, flexibility and improvements in efficiency – combined with the ability to withstand the harshest industrial conditions.

**A new product to
serve your needs.
Be certain.**

RSCIS 4D/9 and BRSCIS 4D/9 Connectors

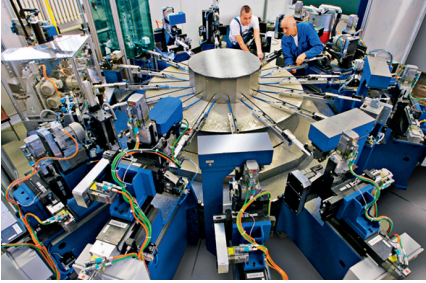

The RSCIS 4D/9 and BRSCIS 4D/9 are M12, male field-attachable connectors – shielded and D-coded for EtherNet/IP and PROFINET applications.

The RSCIS 4D/9 connector will be certified according to UL requirements in the near future and therefore ensures safety and quality requirements for industrial control and signal distribution applications.

The BRSCIS 4D/9 connector, specifically, connects supervisory, security and media systems in trains and rolling stocks where vibration and inflammability create a challenging environmental conditions for reliable networking and connectivity.

Benefits at a Glance

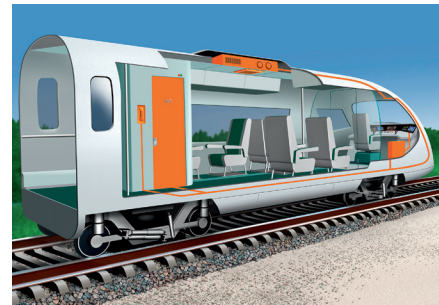

- Efficient establishment of EtherNet/IP and PROFINET connections
- Patented IDC connection characteristics enhance convenience
- Data transfer rate of up to 100 Mbit/s meeting cat5 standard
- Meets IP67 protection rating
- Operates at a temperature range from -40 °C to +85 °C
- Rail-approved version (BRSCIS 4D/9) meets DIN EN 50155, DIN EN 45545-2, DIN EN 50467, DIN EN 61373
- UL-approved version (RSCIS 4D/9) available in near future*
- Color coding of the wiring retainer for easy setup
- Works seamlessly with Belden, Hirschmann and Lumberg Automation Industrial Ethernet products

The BRSCIS 4D/9 connector connects supervisory, security and media systems in trains and rolling stocks.







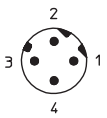
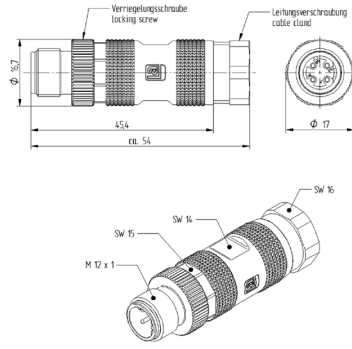





Technical Information

Product Description	
Type	RSCIS 4D/9
	
	
Description	Field attachable connector, M12 male connector, with threaded joint, shielded, assembling with insulation displacement connection, 4 poles, D-coded – UL approved version –
RoHS (2011/65/EU)	yes
Standards	IEC 61076-2-101
Approvals	UL* DIN EN 50155, DIN EN 45545-2, DIN EN 50467, DIN EN 61373
Technical Data	
Environmental Temperature	-40 °C to +85 °C
Housing Material	CuZn, Ni-plated
Contact Bearer Material	PA
Contact Material, Surface Refinement	CuSn, Ni/Au-plated
Knurled Screw/Nut Material	CuZn, Ni-plated
Mechanical Data	
Degree of Protection (IP), Mounted	IP65, IP67 (Only in properly locked position with suitable counterpart)
Electrical Data	
Insulation Resistance	≤ 10 mΩ
Rated Voltage	250 V AC/DC
Rated Current In	4 A
Pollution Degree	3
Technical Drawing	
<p>Pin Assignment</p>  <p>M12, Male 4-poles D-coding</p>	

* Pending UL-approved version (RSCIS 4D/9) will meet UL 2238 (available in near future)

Order Information

Order No.	Type	No. of Contacts	Type of Connection	Conductor Size	Cable Gland	Characteristics
934828002	RSCIS 4D/9	4	IDC	AWG 24, AWG 22	PG 9: Ø 6.0 to 8.0 mm	   
934828001	BRSCIS 4D/9	4	IDC	AWG 24, AWG 22	PG 9: Ø 6.0 to 8.0 mm	   

Belden® Connectivity Center

Nowadays it is more important than ever to continuously increase the efficiency of production processes. Safe, cost-effective connectivity solutions for your machinery and plant play an important role in achieving this. Customized solutions tailored to your individual requirements enable you to substantially reduce your total cost of ownership. Thanks to the Belden Connectivity Center, the only one of its kind in the market, we are your worldwide partner when it comes to implementing such solutions, flexibly and rapidly, whether you need customized connectors and cable assemblies, or active and passive I/O modules for fieldbus or Ethernet networks – always in line with our motto “listen, understand, implement and deliver.” You will benefit both from the expertise of our knowledgeable specialists and from our extensive experience as a leading supplier of high-quality automation components. Let us utilize your challenges for our mutual success.

Always Stay Ahead with Belden

In a highly competitive environment, it is crucial to have reliable partners who are able to add value to your business. When it comes to signal transmissions, Belden is the No. 1 solutions provider. We understand your business and want to know your specific challenges and targets to see how effective signal transmission solutions can push you ahead of the competition. By combining the strengths of our five leading brands, Belden®, GarrettCom®, Hirschmann™, Lumberg Automation™ and Tofino™ Security, we are able to offer the solution you need. Today, it may be a single cable, a switch or a connector, thus solving a specific issue; tomorrow, it can be a complex range of integrated applications, systems and solutions.